

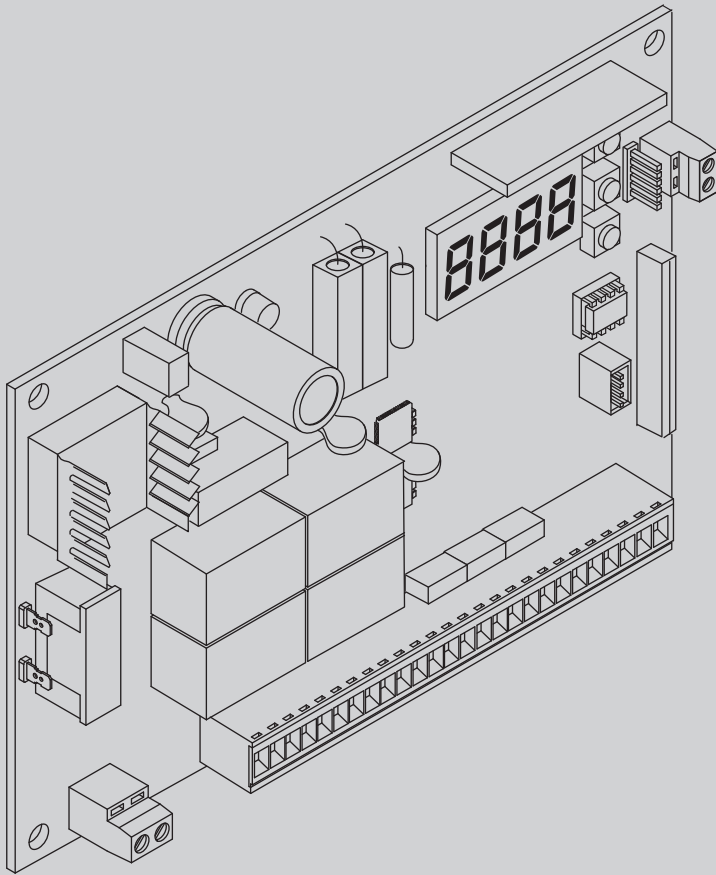

QUADRO COMANDO
 CONTROL PANEL
 CENTRALE DE COMMANDE
 SELBSTÜBERWACHENDE STEUERUNG
 CUADRO DE MANDOS
 BEDIENINGSPANEEL



THALIA

ISTRUZIONI DI INSTALLAZIONE
 INSTALLATION MANUAL
 INSTRUCTIONS D'INSTALLATION
 MONTAGEANLEITUNG
 INSTRUCCIONES DE INSTALACION
 INSTALLATIEVOORSCHRIFTEN

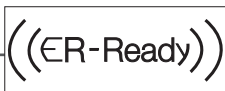

AZIENDA CON SISTEMA DI GESTIONE
 INTEGRATO CERTIFICATO DA DNV
 = UNI EN ISO 9001:2008 =
 UNI EN ISO 14001:2004

INSTALLAZIONE VELOCE-QUICK INSTALLATION-INSTALLATION RAPIDE SCHNELLINSTALLATION-INSTALACIÓN RÁPIDA - SNELLE INSTALLATIE

D811762.00100_02

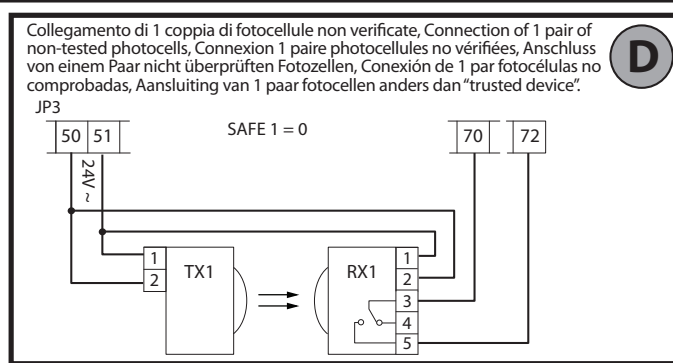
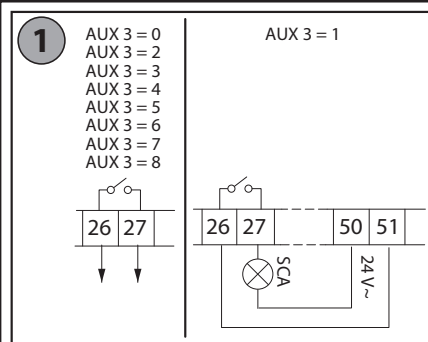
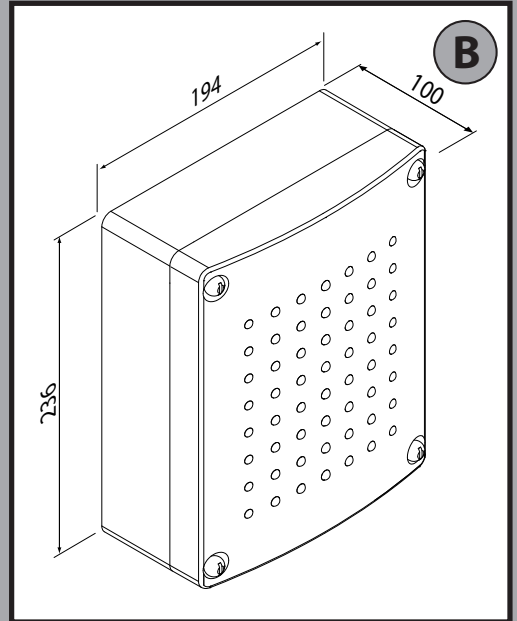
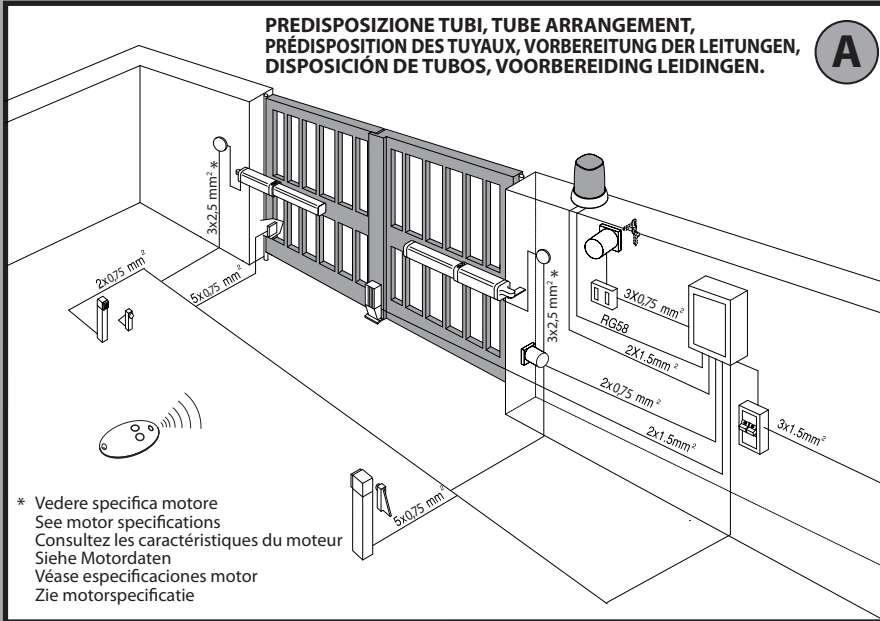

Connettore scheda opzionale,
SCS1 optional board connector,
Connecteur carte facultative,
Steckverbinder Zusatzkarte,
Conector de la tarjeta opcional,
Connector optionele kaart.

Connettore programmatore palmare,
Palmtop programmer connector,
Connecteur programmeur de poche,
Steckverbinder Palmtop-Programmierer,
Conector del programador de bolsillo,
Connector programmeerbare palmtop.

Display + tasti programmazione,
Display plus programming keys,
Afficheur et touches de programmation,
Display und Programmierungstasten,
Pantalla mas botones de programacion,
Display meerdere toetsen programmeren.

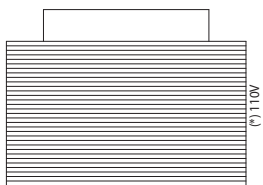

* Altre tensioni disponibili a richiesta
Other voltages available on request
Autres tensions disponibles sur demande
Weitere Spannungen auf Anfrage erhältlich
Otras tensiones disponibles a petición
Andere spanningen op aanvraag beschikbaar

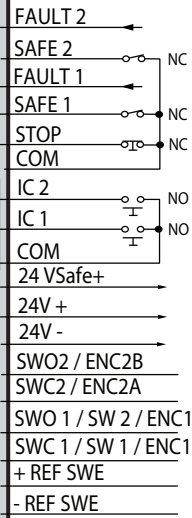
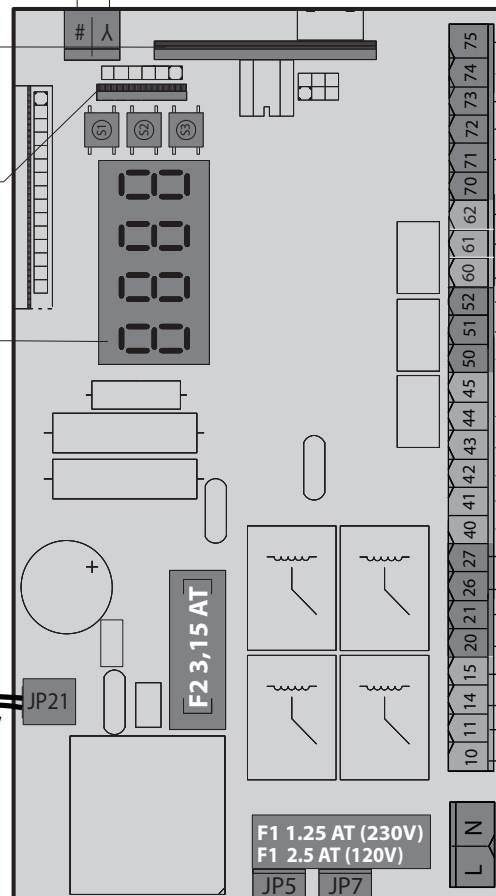

Sicurezze
Safety devices
Sécurité
Sicherheitsvorrichtungen
Dispositivos de seguridad
Veiligheden

Comandi / Commands
Commandes/Bedienelemente
Mandos/ Commando's

Alimentazione accessori
Accessories power supply
Alimentation des accessoires
Stromversorgung Zubehör
Alimentación accesorios
Voeding accessoires

Ingressi finecorsa/encoder
Encoder/limit switch inputs
Entrées des fins de course/encodeur
Eingänge Anschlag/Encoder
Entradas finales de carrera
Encoder/ingangen

AUX

Motore / Motor / moteur
Motor /Eindaanslag/Encoder

Alimentazione / Power supply
Alimentation / Stromversorgung
Alimentación /Voeding

ἔ ἰΡο ΠοτορΕ - ἔΥΡΕ dE ΠοτΕῦρ - ΠοτορΕνἔΥΡ - Ποτορ ἔΥΡΕ - ἔ ἰΡο Ποτορ: 1

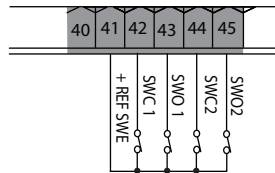
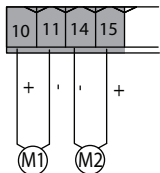
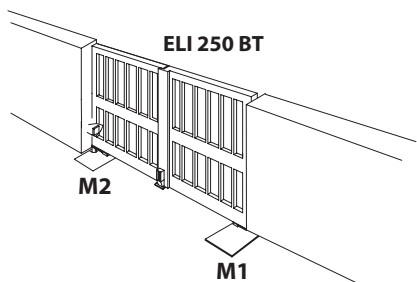

ἔ ἰΡο ΠοτορΕ - ἔΥΡΕ dE ΠοτΕῦρ - ΠοτορΕνἔΥΡ - Ποτορ ἔΥΡΕ - ἔ ἰΡο Ποτορ: 2

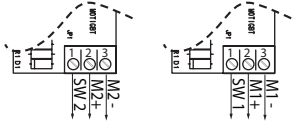
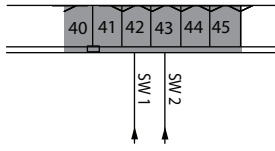
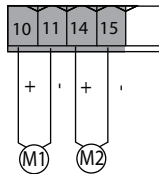
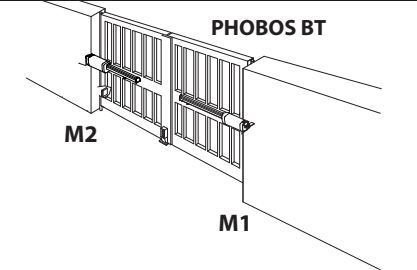

ἔ ἰΡο ΠοτορΕ - ἔΥΡΕ dE ΠοτΕῦρ - ΠοτορΕνἔΥΡ - Ποτορ ἔΥΡΕ - ἔ ἰΡο Ποτορ: 3

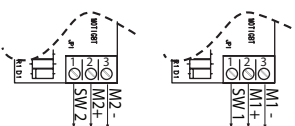
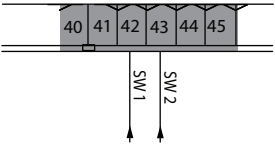
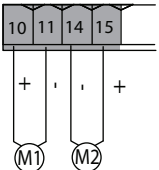
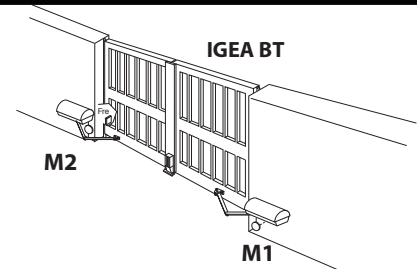

SIMPLIFIED MENU

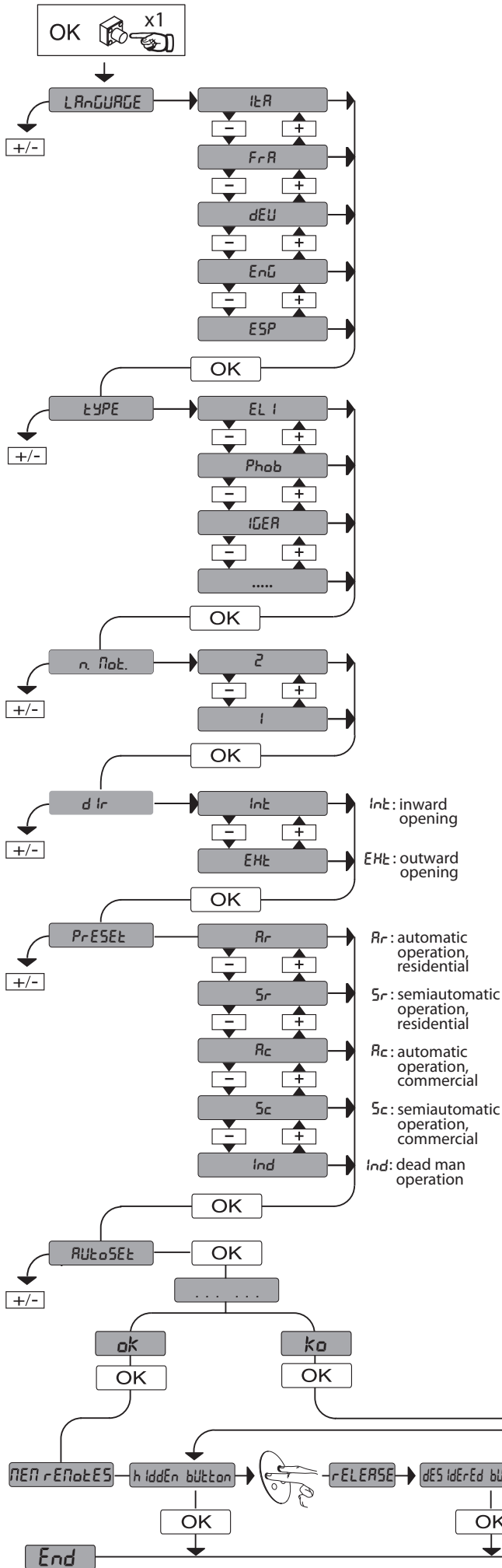

PRESET	DEFAULT	Rr	Sr	Rc	Sc	ind
PARAMETERS						
Motor 2 opening delay time [s]	1	0	0	1	1	1
Motor 1 closing delay time [s]	1	0	0	1	1	1
Automatic closing time [s]	10	10	10	10	10	10
Time-to-clear traffic light zone [s]	40	40	40	40	40	40
Slow-down distance during opening [%]	10	10	10	10	10	10
Slow-down distance during closing [%]	10	10	10	10	10	10
Deceleration distance [%]	15	15	15	15	15	15
Leaf force during opening [%]	50	50	50	50	50	50
Leaf force during closing [%]	50	50	50	50	50	50
Opening speed [%]	99	99	99	99	99	99
Closing speed [%]	99	99	99	99	99	99
Slow-down speed [%]	25	25	25	25	25	25
LOGIC						
Motor type	0	/	/	/	/	/
Automatic Closing Time	0	1	0	1	1	0
Fast closing	0	0	0	0	0	0
Step-by-step movement	0	1	0	1	0	0
Pre-alarm	0	0	0	1	1	0
Deadman	0	0	0	0	0	1
Block pulses during opening	0	0	0	1	1	0
Block pulses during TCA	0	0	0	0	0	0
Closing limit switch pressure	0	0	0	0	0	0
1 motor active	0	/	/	/	/	/
Open in other direction	0	/	/	/	/	/
SAFE 1	0	/	/	/	/	/
SAFE 2	6	/	/	/	/	/
IC 1	0	/	/	/	/	/
IC 2	4	/	/	/	/	/
AUX 3	0	/	/	/	/	/
Fixed code	0	0	0	0	0	0
Transmitter programming	1	1	1	1	1	0
Serial mode	0	0	0	0	0	0
Address	0	0	0	0	0	0
EXPI1	1	/	/	/	/	/
EXPI2	0	/	/	/	/	/
EXPO1	9	/	/	/	/	/
EXPO2	9	/	/	/	/	/
Traffic light pre-flashing	0	0	0	0	0	0
Steadily lit red light	0	0	0	0	0	0

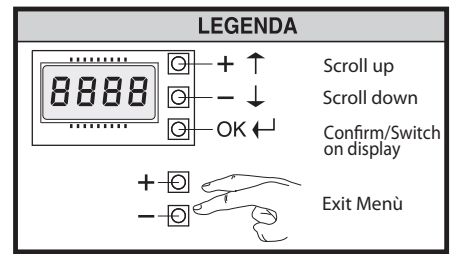
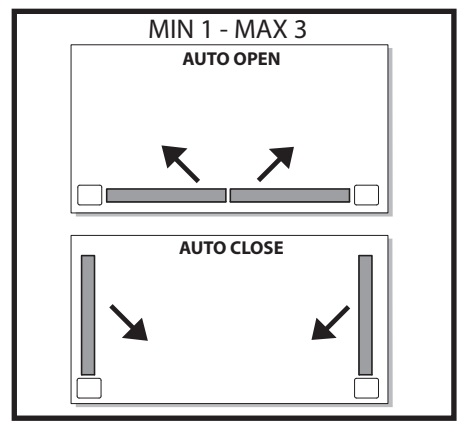

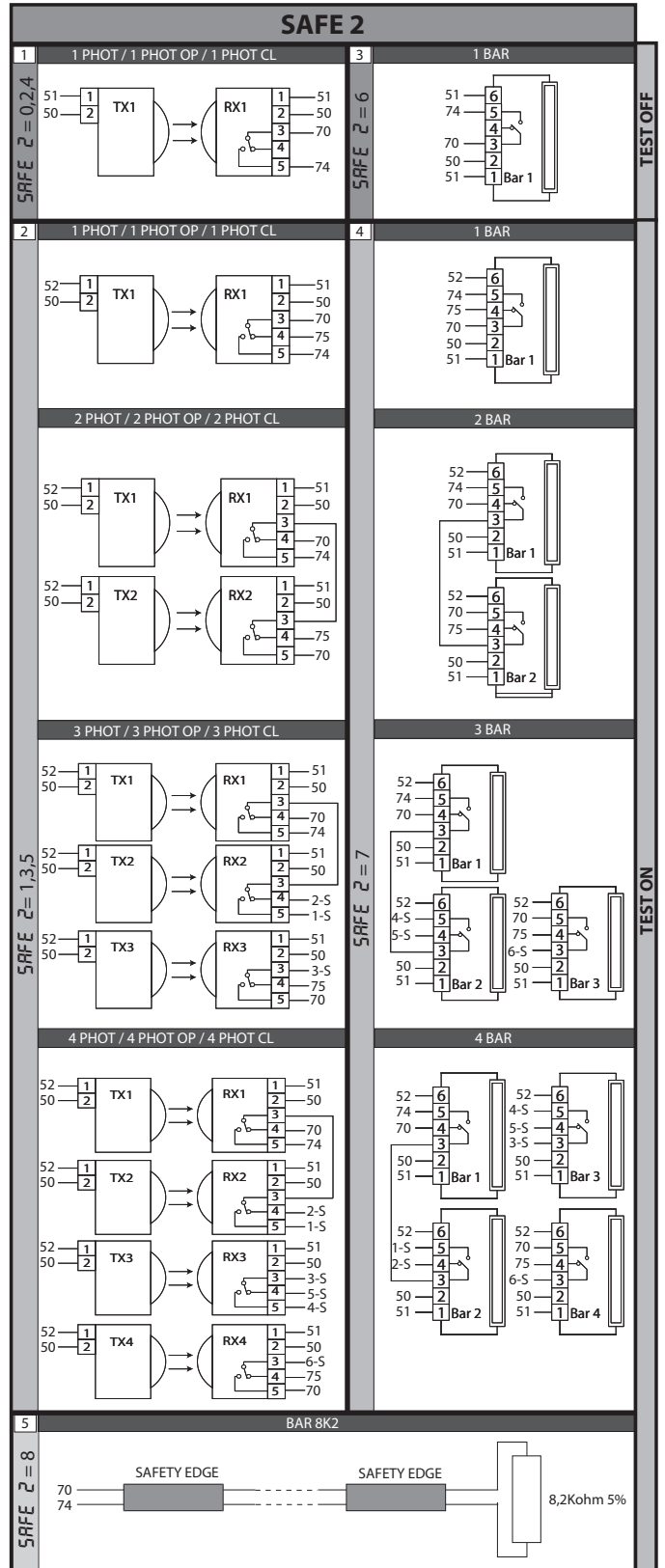
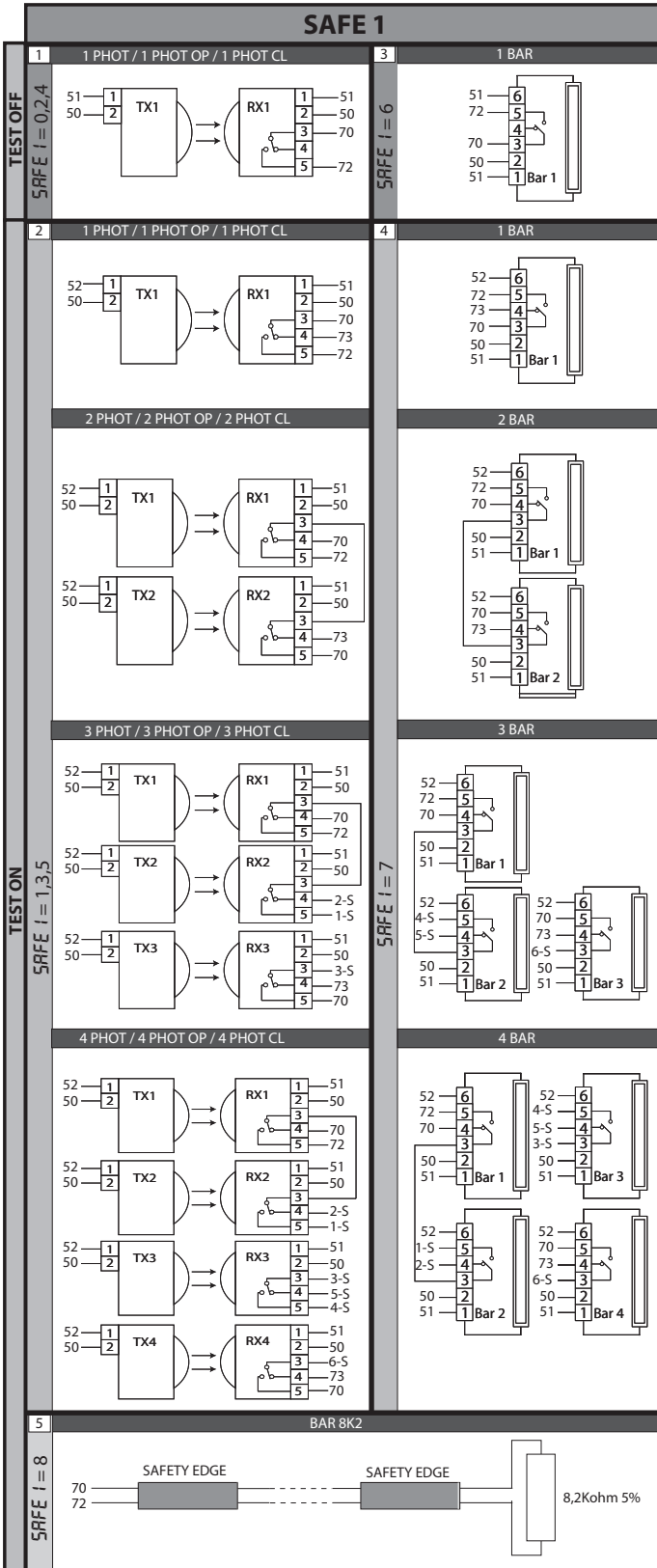
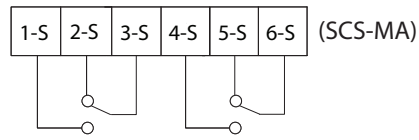
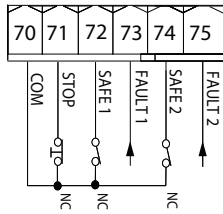
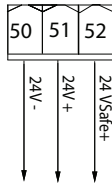

Numero massimo di dispositivi verificati: 6 (ma non più di 4 per tipo),
 Maximum number of tested devices: 6 (but no more than 4 per type),
 Nombre maximum dispositif vérifiés: 6 (mais pas plus de 4 par type),
 Max. Anzahl der überprüften Geräte: 6 (jedoch nicht mehr als 4 je Typ),
 Número máximo dispositivos comprobados: 6 (pero no más de 4 por tipo),
 Maximumaantal "trusted devices": 6 (maar niet meer dan 4 per type).

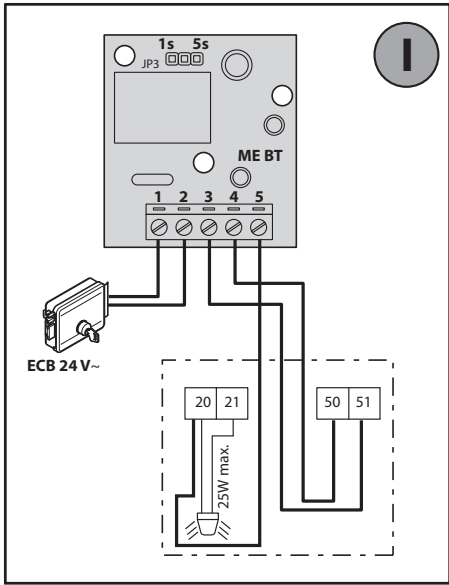
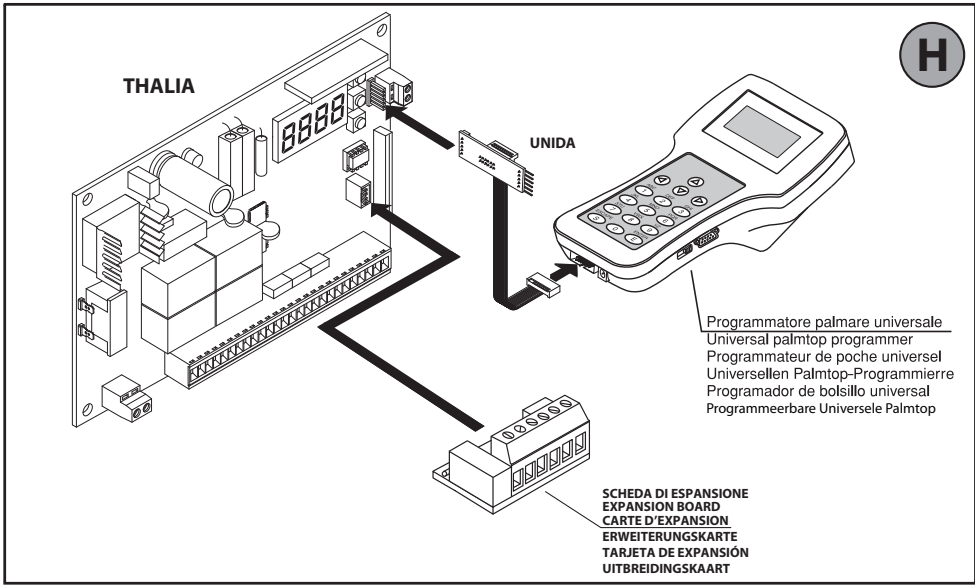
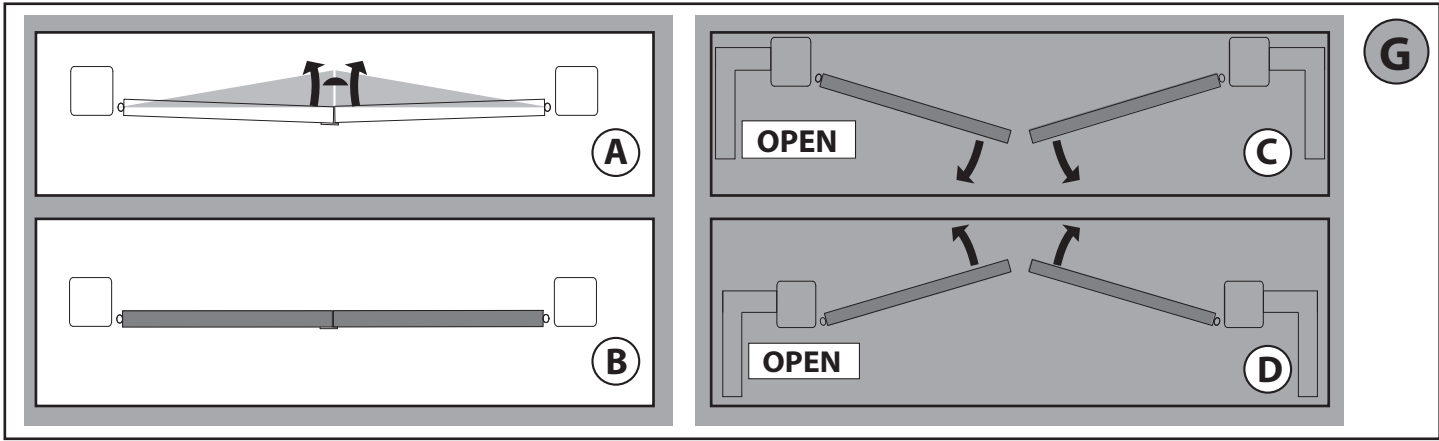

ACCESS MENUS Fig. 1

D811762 00100_02

LEGENDA

- + ↑ Scroll up
- ↓ Scroll down
- OK ↵ Confirm Switch on display
- +/- Exit Menu

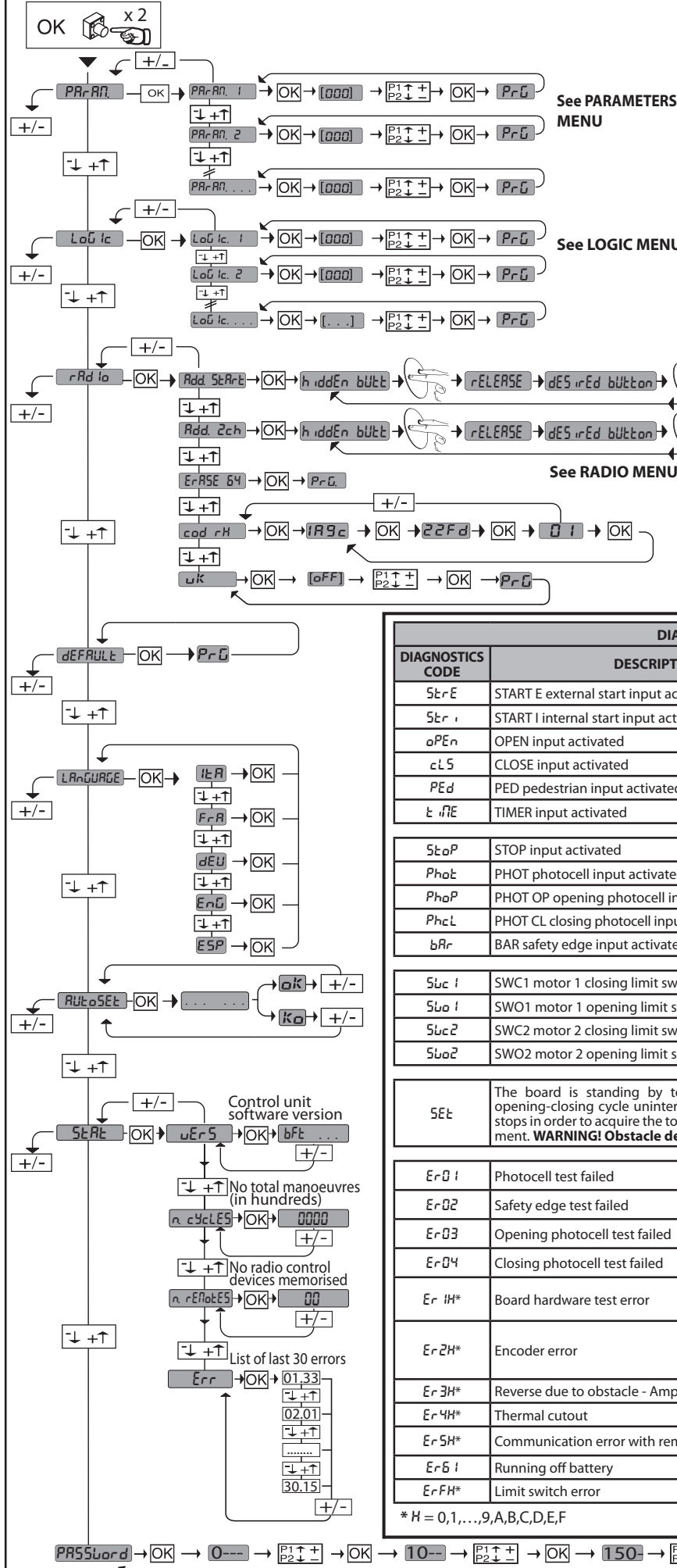

3540

- Instantaneous force motor 2
- Instantaneous force motor 1

DIAGNOSTICS and WARNINGS		
DIAGNOSTICS CODE	DESCRIPTION	NOTES
StErE	START E external start input activated	
StEr I	START I internal start input activated	
aPEn	OPEN input activated	
cLS	CLOSE input activated	
PEd	PED pedestrian input activated	
t. rTE	TIMER input activated	
StoP	STOP input activated	
Phot	PHOT photocell input activated	
PhoP	PHOT OP opening photocell input activated	
PhcL	PHOT CL closing photocell input activated	
bAr	BAR safety edge input activated	
Sbc 1	SWC1 motor 1 closing limit switch input activated	
Sbo 1	SWO1 motor 1 opening limit switch input activated	
Sbc 2	SWC2 motor 2 closing limit switch input activated	
Sbo 2	SWO2 motor 2 opening limit switch input activated	
SEt	The board is standing by to perform a complete opening-closing cycle uninterrupted by intermediate stops in order to acquire the torque required for movement. WARNING! Obstacle detection not active.	
Er01	Photocell test failed	Check photocell connection and/or logic settings
Er02	Safety edge test failed	Check safety edge connection and/or logic settings
Er03	Opening photocell test failed	Check photocell connection and/or parameter/logic setting
Er04	Closing photocell test failed	Check photocell connection and/or parameter/logic setting
Er1H*	Board hardware test error	- Check connections to motor - Hardware problems with board (contact technical assistance)
Er2H*	Encoder error	- Motor power or encoder signal cables inverted/disconnected. - Actuator movement is too slow or stopped with respect to programmed operation.
Er3H*	Reverse due to obstacle - Amperostop	Check for obstacles in path
Er4H*	Thermal cutout	Allow automated device to cool
Er5H*	Communication error with remote devices	Check connection with serial-connected accessory devices and/or expansion boards
Er61	Running off battery	--
ErFH*	Limit switch error	Check limit switch connections

* H = 0,1,...,9,A,B,C,D,E,F

INSTALLER WARNINGS

WARNING! Important safety instructions. Carefully read and comply with all the warnings and instructions that come with the product as incorrect installation can cause injury to people and animals and damage to property. The warnings and instructions give important information regarding safety, installation, use and maintenance. Keep hold of instructions so that you can attach them to the technical file and keep them handy for future reference.

GENERAL SAFETY

This product has been designed and built solely for the purpose indicated herein. Uses other than those indicated herein might cause damage to the product and create a hazard.

- The units making up the machine and its installation must meet the requirements of the following European Directives, where applicable: 2004/108/EC, 2006/95/EC, 2006/42/EC, 89/106/EC, 99/05/EC and later amendments. For all countries outside the EEC, it is advisable to comply with the standards mentioned, in addition to any national standards in force, to achieve a good level of safety.
- The Manufacturer of this product (hereinafter referred to as the "Firm") disclaims all responsibility resulting from improper use or any use other than that for which the product has been designed, as indicated herein, as well as for failure to apply Good Practice in the construction of entry systems (doors, gates, etc.) and for deformation that could occur during use.
- Installation must be carried out by qualified personnel (professional installer, according to EN 12635), in compliance with Good Practice and current code.
- Before commencing installation, check the product for damage.
- Before installing the product, make all structural changes required to produce safety gaps and to provide protection from or isolate all crushing, shearing and dragging hazard areas and danger zones in general. Check that the existing structure meets the necessary strength and stability requirements.
- The Firm is not responsible for failure to apply Good Practice in the construction and maintenance of the doors, gates, etc. to be motorized, or for deformation that might occur during use.
- Make sure the stated temperature range is compatible with the site in which the automated system is due to be installed.
- Do not install this product in an explosive atmosphere: the presence of flammable fumes or gas constitutes a serious safety hazard.
- Disconnect the electricity supply before performing any work on the system. Also disconnect buffer batteries, if any are connected.
- Before connecting the power supply, make sure the product's ratings match the mains ratings and that a suitable residual current circuit breaker and overcurrent protection device have been installed upline from the electrical system. Have the automated system's mains power supply fitted with a switch or omnipolar thermal-magnetic circuit breaker with a contact separation of at least 3.0mm and any other equipment required by code.
- Make sure that upline from the mains power supply there is a residual current circuit breaker that trips at no more than 0.03A as well as any other equipment required by code.
- Make sure the earth system has been installed correctly: earth all the metal parts belonging to the entry system (doors, gates, etc.) and all parts of the system featuring an earth terminal.
- Installation must be carried out using safety devices and controls that meet standards EN 12978 and EN 12453.
- Impact forces can be reduced by using deformable edges.
- In the event impact forces exceed the values laid down by the relevant standards, apply electro-sensitive or pressure-sensitive devices.
- Apply all safety devices (photocells, safety edges, etc.) required to keep the area free of impact, crushing, dragging and shearing hazards. Bear in mind the standards and directives in force, Good Practice criteria, intended use, the installation environment, the operating logic of the system and forces generated by the automated system.
- Apply all signs required by current code to identify hazardous areas (residual risks). All installations must be visibly identified in compliance with the provisions of standard EN 13241-1.
- This product cannot be installed on leaves incorporating doors (unless the motor can be activated only when the door is closed).
- If the automated system is installed at a height of less than 2.5 m or is accessible, the electrical and mechanical parts must be suitably protected.
- Install any fixed controls in a position where they will not cause a hazard, away from moving parts. More specifically, hold-to-run controls must be positioned within direct sight of the part being controlled and, unless they are key operated, must be installed at a height of at least 1.5 m and in a place where they cannot be reached by the public.
- Apply at least one warning light (flashing light) in a visible position, and also attach a Warning sign to the structure.
- Attach a label near the operating device, in a permanent fashion, with information on how to operate the automated system's manual release.
- Make sure that, during operation, mechanical risks are avoided or relevant protective measures taken and, more specifically, that nothing can be banged, crushed, caught or cut between the part being operated and surrounding parts.
- Once installation is complete, make sure the motor automation settings are correct and that the safety and release systems are working properly.
- Only use original spare parts for any maintenance or repair work. The Firm disclaims all responsibility for the correct operation and safety of the automated system if parts from other manufacturers are used.
- Do not make any modifications to the automated system's components unless explicitly authorized by the Firm.
- Instruct the system's user on what residual risks may be encountered, on the control systems that have been applied and on how to open the system manually in an emergency. Give the user guide to the end user.
- Dispose of packaging materials (plastic, cardboard, polystyrene, etc.) in accordance with the provisions of the laws in force. Keep nylon bags and polystyrene out of reach of children.

WIRING

WARNING! For connection to the mains power supply, use a multicore cable with a cross-sectional area of at least 4x1.5mm² of the kind provided for by the regulations mentioned above (by way of example, type H05 VV-F cable can be used with a cross-sectional area of 4x1.5mm²). To connect auxiliary equipment, use wires with a cross-sectional area of at least 0.5 mm².

- Only use pushbuttons with a capacity of 10A-250V or more.
- Wires must be secured with additional fastening near the terminals (for example, using cable clamps) in order to keep live parts well separated from safety extra low voltage parts.
- During installation, the power cable must be stripped to allow the earth wire to be connected to the relevant terminal, while leaving the live wires as short as possible. The earth wire must be the last to be pulled taut in the event the cable's fastening device comes loose.

WARNING! safety extra low voltage wires must be kept physically separate from low voltage wires.

Only qualified personnel (professional installer) should be allowed to access live parts.

CHECKING THE AUTOMATED SYSTEM AND MAINTENANCE

Before the automated system is finally put into operation, and during maintenance work, perform the following checks meticulously:

- Make sure all components are fastened securely.
- Check starting and stopping operations in the case of manual control.
- Check the logic for normal or personalized operation.
- For sliding gates only: check that the rack and pinion mesh correctly with 2 mm of play; keep the track the gate slides on clean and free of debris at all times.
- Check that all safety devices (photocells, safety edges, etc.) are working properly and that the anti-crush safety device is set correctly, making sure that the force of impact measured at the points provided for by standard EN 12445 is lower than the value laid down by standard EN 12453.
- Make sure that the emergency operation works, where this feature is provided.
- Check opening and closing operations with the control devices applied.
- Check that electrical connections and cabling are intact, making extra sure that insulating sheaths and cable glands are undamaged.
- While performing maintenance, clean the photocells' optics.
- When the automated system is out of service for any length of time, activate the emergency release (see "EMERGENCY OPERATION" section) so that the operated part is made idle, thus allowing the gate to be opened and closed manually.

SCRAPPING

Materials must be disposed of in accordance with the regulations in force. There are no particular hazards or risks involved in scrapping the automated system. For the purpose of recycling, it is best to separate dismantled parts into like materials (electrical parts - copper - aluminium - plastic - etc.).

DISMANTLING

If the automated system is being dismantled in order to be reassembled at another site, you are required to:

- Cut off the power and disconnect the whole electrical system.
- Remove the actuator from the base it is mounted on.
- Remove all the installation's components.
- See to the replacement of any components that cannot be removed or happen to be damaged.

Anything that is not explicitly provided for in the installation manual is not allowed. The operator's proper operation can only be guaranteed if the information given is complied with. The Firm shall not be answerable for damage caused by failure to comply with the instructions featured herein.

While we will not alter the product's essential features, the Firm reserves the right, at any time, to make those changes deemed opportune to improve the product from a technical, design or commercial point of view, and will not be required to update this publication accordingly.

2) GENERAL INFORMATION

The **THALIA** control panel comes with standard factory settings. Any change must be made using the programmer with built-in display or universal handheld programmer. Fully supports EELINK protocol.

Its main features are:

- Control of 1 or 2 24V BT motors
- Note: 2 motors of the same type must be used.
- Electronic torque control with obstacle detection
- Limit switch control inputs based on motor selected
- Separate inputs for safety devices
- Built-in radio receiver rolling code with transmitter cloning.

The board has a terminal strip of the removable kind to make maintenance or replacement easier. It comes with a series of prewired jumpers to make the installer's job on site easier.

The jumpers concern terminals: 70-71, 70-72, 70-74. If the above-mentioned terminals are being used, remove the relevant jumpers.

TESTING

The **THALIA** panel controls (checks) the start relays and safety devices (photocells) before performing each opening and closing cycle.

If there is a malfunction, make sure that the connected devices are working properly and check the wiring.

3) TECHNICAL SPECIFICATIONS	
Power supply	230V~ ±10% 50Hz*
Low voltage/mains insulation	> 2MΩm 500V ---
Operating temperature range	-10 / +55°C
Thermal overload protection	Software
Dielectric rigidity	mains/LV 3750V~ for 1 minute
Motor output current	max. 7.5A+7.5A
Motor relay switching current	10A
Maximum motor power	180W + 180W (24V ---)

Accessories power supply	24V~ (demand max. 180mA) 24V~safe (demand max. 180mA)
AUX 3	NO contact (24V~/max.1A)
Flashing light	24V~ max. 25W
Dimensions	see Fig. B
Fuses	see Fig. C
N° of combinations:	4 billion
Max. n° of transmitters that can be memorized:	63

(*other voltages to order)

Usable transmitter versions:

All ROLLING CODE transmitters compatible with ((€R-Ready))

4) TUBE ARRANGEMENT Fig. A

5) TERMINAL BOARD WIRING Fig. C

WARNINGS - When performing wiring and installation, refer to the standards in force and, whatever the case, apply good practice principles.

Wires carrying different voltages must be kept physically separate from each other, or they must be suitably insulated with at least 1mm of additional insulation.

Wires must be secured with additional fastening near the terminals, using devices such as cable clamps.

All connecting cables must be kept far enough away from the dissipater.

WARNING! For connection to the mains power supply, use a multicore cable with a cross-sectional area of at least 3x1.5mm² of the kind provided for by the regulations in force.

To connect the motors, use a cable with a cross-sectional area of at least 1.5mm² of the kind provided for by the regulations in force. By way of example, if the cable is run outside (unprotected), it must be at least type H07RN-F, while if it is run inside (in a raceway), it must be at least type H05 VV-F.

	TERM.	DEFINITION	DESCRIPTION
Power supply	L	LINE	Single-phase power supply 230V~ ±10%, 50-60Hz.
	N	NEUTRAL	
	JP5	TRANSF PRIM	Transformer primary winding connection, 230V.
	JP7		
	JP21	TRANSF SEC	Board power supply: 24V~ Transformer secondary winding 24V= Buffer battery power supply
Motor	10	MOT1 +	Connection motor 1. Time lag during closing.
	11	MOT1 -	
	14	MOT2 +	Connection motor 2. Time lag during opening.
	15	MOT2 -	
Aux	20	LIGHT 24V	Flashing light 24V output max. 25W.
	21		
	26	AUX 3 - FREE CONTACT (N.O.) (Max 24V 3W)	Aux 3 logic= 0 - 2nd radio channel output. Contact stays closed for 1s when 2nd radio channel is activated.
			Aux 3 logic= 1 - SCA Gate Open Light output. Contact stays closed during opening and with leaf open, intermittent during closing, open with leaf closed. In this case, the 2nd radio channel controls pedestrian opening.
			Aux 3 logic= 2 - Courtesy light command output. Contact stays on for 90 seconds after the last operation. In this case, the 2nd radio channel controls pedestrian opening.
			Aux 3 logic= 3 - Zone light command output. Contact stays closed for the full duration of operation. In this case, the 2nd radio channel controls pedestrian opening.
			Aux 3 logic= 4 - Stair light output. Contact stays closed for 1 second at start of operation. In this case, the 2nd radio channel controls pedestrian opening.
			Aux 3 logic= 5 - Gate open alarm output. Contact stays closed if the leaf stays open for double the set TCA time. In this case, the 2nd radio channel controls pedestrian opening.
			Aux 3 logic= 6 - Flashing light output. Contact stays closed while leaves are operating. In this case, the 2nd radio channel controls pedestrian opening.
			Aux 3 logic= 7 - Solenoid latch output. Contact stays closed for 2 seconds each time gate is opened. In this case, the 2nd radio channel controls pedestrian opening.
27		Aux 3 logic= 8 - Magnetic lock output. Contact stays closed while gate is closed. In this case, the 2nd radio channel controls pedestrian opening.	
Limit switch for ELI 250 BT	41	+ REF SWE	Limit switch common
	42	SWC 1	Motor 1 closing limit switch SWC1 (N.C.).
	43	SWO 1	Motor 1 opening limit switch SWO1 (N.C.).
	44	SWC 2	Motor 2 closing limit switch SWC2 (N.C.).
	45	SWO 2	Motor 2 opening limit switch SWO2 (N.C.).
Limit switch for PHOBOS BT - IGEA BT	42	SW 1	Limit switch control motor 1. For actuators with single-wire limit switch control.
	43	SW 2	Limit switch control motor 2. For actuators with single-wire limit switch control.
Accessories power supply	50	24V-	Accessories power supply output.
	51	24V+	
	52	24 Vsafe+	Tested safety device power supply output (photocell transmitter and safety edge transmitter). Output active only during operating cycle.

INSTALLATION MANUAL

Commands	60	Common	IC 1 and IC 2 inputs common
	61	IC 1	Configurable command input 1 (N.O.) - Default START E. START E / START I / OPEN / CLOSE / PED / TIMER / TIMER PED. Refer to the "Command input configuration" table.
	62	IC 2	Configurable command input 2 (N.O.) - Default PED. START E / START I / OPEN / CLOSE / PED / TIMER / TIMER PED. Refer to the "Command input configuration" table.

Safety devices	70	COMMON	STOP, SAFE 1 and SAFE 2 inputs common
	71	STOP	The command stops movement. (N.C.) If not used, leave jumper inserted.
	72	SAFE 1	Configurable safety input 1 (N.C.) - Default PHOT. PHOT / PHOT TEST / PHOT OP / PHOT OP TEST / PHOT CL / PHOT CL TEST / BAR / BAR TEST / BAR 8K2. Refer to the "Safety input configuration" table.
	73	FAULT 1	Test input for safety devices connected to SAFE 1.
	74	SAFE 2	Configurable safety input 2 (N.C.) - Default BAR. PHOT / PHOT TEST / PHOT OP / PHOT OP TEST / PHOT CL / PHOT CL TEST / BAR / BAR TEST / BAR 8K2. Refer to the "Safety input configuration" table.
	75	FAULT 2	Test input for safety devices connected to SAFE 2.

Antenna	Y	ANTENNA	Antenna input.
	#	SHIELD	Use an antenna tuned to 433MHz. Use RG58 coax cable to connect the Antenna and Receiver. Metal bodies close to the antenna can interfere with radio reception. If the transmitter's range is limited, move the antenna to a more suitable position.

Command input configuration

IC logic= 0 - Input configured as Start E. Operation according to STEP-BY-STEP MOV. logic. External start for traffic light control.

IC logic= 1 - Input configured as Start I. Operation according to STEP-BY-STEP MOV. logic. Internal start for traffic light control.

IC logic= 2 - Input configured as Open. The command causes the leaves to open. If the input stays closed, the leaves stay open until the contact is opened. When the contact is open, the automated device closes following the TCA time, where activated.

IC logic= 3 - Input configured as Closed. The command causes the leaves to close.

IC logic= 4 - Input configured as Ped. The command causes the leaf to open to the pedestrian (partial) opening position. Operation according to STEP-BY-STEP MOV. logic

IC logic= 5 - Input configured as Timer. Operation same as open except closing is guaranteed even after a mains power outage.

IC logic= 6 - Input configured as Timer Ped. The command causes the leaf to open to the pedestrian (partial) opening position. If the input stays closed, the leaf stays open until the contact is opened. If the input stays closed and a Start E, Start I or Open command is activated, a complete opening-closing cycle is performed before returning to the pedestrian opening position. Closing is guaranteed even after a mains power outage.

Safety input configuration

SAFE logic= 0 - Input configured as Phot (photocell)(Fig.F Rif.1). Enables connection of devices not equipped with supplementary test contacts. When beam is broken, photocells are active during both opening and closing. When beam is broken during closing, movement is reversed only once the photocell is cleared. If not used, leave jumper inserted.

SAFE logic= 1 - Input configured as Phot test (tested photocell) (Fig.F Rif.2). Switches photocell testing on at start of operation. When beam is broken, photocells are active during both opening and closing. When beam is broken during closing, movement is reversed only once the photocell is cleared.

SAFE logic= 2 - Input configured as Phot op (photocell active during opening only) (Fig.F Rif.1). Enables connection of devices not equipped with supplementary test contacts. In the event beam is broken, photocell operation is disabled during closing. During opening, stops motion for as long as the photocell beam stays broken. If not used, leave jumper inserted.

SAFE logic= 3 - Input configured as Phot op test (tested photocell active during opening only) (Fig.F Rif.2). Switches photocell testing on at start of operation. In the event beam is broken, photocell operation is disabled during closing. During opening, stops motion for as long as the photocell beam stays broken.

SAFE logic= 4 - Input configured as Phot cl (photocell active during closing only) (Fig.F Rif.1). Enables connection of devices not equipped with supplementary test contacts. In the event beam is broken, photocell operation is disabled during opening. During closing, movement is reversed immediately. If not used, leave jumper inserted.

SAFE logic= 5 - Input configured as Phot cl test (tested photocell active during closing only) (Fig.F Rif.2). Switches photocell testing on at start of operation. In the event beam is broken, photocell operation is disabled during opening. During closing, movement is reversed immediately.

SAFE logic= 6 - Input configured as Bar (safety edge) (Fig.F Rif.3). Enables connection of devices not equipped with supplementary test contacts. The command reverses movement for 2 sec.. If not used, leave jumper inserted.

SAFE logic= 7 - Input configured as Bar (tested safety edge) (Fig.F Rif.4). Switches safety edge testing on at start of operation. The command reverses movement for 2 sec.

SAFE logic= 8 - Input configured as Bar 8k2 (Fig.F Rif.5). Input for resistive edge 8K2. The command reverses movement for 2 sec.

6) MOTOR WIRING Fig. E

7) SAFETY DEVICES

Note: only use receiving safety devices with free changeover contact.

7.1) TESTED DEVICES Fig. F

7.2) CONNECTION OF 1 PAIR OF NON-TESTED PHOTOCELLS FIG. D

8) CALLING UP MENUS: FIG. 1

8.1) PARAMETERS MENU (PARAMETERS TABLE "A")

8.2) LOGIC MENU (LOGIC TABLE "B")

8.3) RADIO MENU (RADIO TABLE "C")

- IMPORTANT NOTE: THE FIRST TRANSMITTER MEMORIZED MUST BE IDENTIFIED BY ATTACHING THE KEY LABEL (MASTER).

In the event of manual programming, the first transmitter assigns the RECEIVER'S KEY CODE: this code is required to subsequently clone the radio transmitters. The Clonix built-in on-board receiver also has a number of important advanced features:

- Cloning of master transmitter (rolling code or fixed code).
- Cloning to replace transmitters already entered in receiver.

- Transmitter database management.
- Receiver community management.

To use these advanced features, refer to the universal handheld programmer's instructions and to the general receiver programming guide.

8.4) DEFAULT MENU (DEFAULT)

Restores the controller's DEFAULT factory settings. Following this reset, you will need to run the AUTOSSET function again.

8.5) LANGUAGE MENU (LANGUAGE)

Used to set the programmer's language on the display.

8.6) AUTOSSET MENU (AUTOSSET)

- Launch an autotest operation by going to the relevant menu.
- As soon as you press the OK button, the "... .." message is displayed and the control unit commands the device to perform a full cycle (opening followed by closing), during which the minimum torque value required to move the leaf is set automatically.

The number of cycles required for the autotest function can range from 1 to 3. During this stage, it is important to avoid breaking the photocells' beams and not to use the START and STOP commands or the display. Once this operation is complete, the control unit will have automatically set the optimum torque values. Check them and, where necessary, edit them as described in the programming section.

⚠ WARNING!! Check that the force of impact measured at the points provided for by standard EN 12445 is lower than the value laid down by standard EN 12453.

⚠ Warning!! While the autoset function is running, the obstacle detection function is not active. Consequently, the installer must monitor the automated system's movements and keep people and property out of range of the automated system.

8.7) STATISTICS MENU

Used to view the version of the board, the total number of operations (in hundreds), the number of transmitters memorized and the last 30 errors (the first 2 digits indicate the position, the last 2 give the error code). Error 01 is the most recent.

8.8) PASSWORD MENU

Used to set a password for the board's wireless programming.

9) CLOSING LIMIT SWITCH PRESSURE Fig. G Ref. A-B OPENING DIRECTION Fig. G Ref. C-D

10) CONNECTION WITH EXPANSION BOARDS AND UNIVERSAL HANDHELD PROGRAMMER VERSION> V1.40 (Fig. H) Refer to specific manual.

11) SOLENOID LOCK Fig. I SOLENOID LOCK

⚠ WARNING: In the case of leaves longer than 3m, it is essential to install a solenoid lock.

Fig. I shows a sample connection of an ECB 24V~ solenoid latch connected to the THALIA control panel.

In order to control the solenoid lock, the THALIA panel needs a special board mod. ME BT.

⚠ WARNING! Incorrect settings can result in damage to property and injury to people and animals.

⚠ WARNING: Check that the force of impact measured at the points provided for by standard EN 12445 is lower than the value laid down by standard EN 12453.

For best results, it is advisable to run the autoset function with the motors idle (i.e. not overheated by a considerable number of consecutive operations).



TABLE "A" - PARAMETERS MENU - (PR-RF)

Parameter	min.	max.	Default	Personal	Definition	Description
oPEn dELAY tIME	0	10	1		Motor 2 opening delay time [s]	Motor 2 opening delay time with respect to motor 1.
cLS dELAY tIME	0	25	1		Motor 1 closing delay time [s]	Motor 1 closing delay time with respect to motor 2.
tCR	0	120	10		Automatic closing time [s]	Waiting time before automatic closing.
tRFLGhtCLrL	1	180	40		Time-to-clear traffic light zone [s]	Time-to-clear for the zone run through by traffic controlled by the traffic light.
oPd iStSLoUd	0	50	10		Slow-down distance during opening [%]	Slow-down distance for motor(s) during opening, given as a percentage of total travel. WARNING: Once the parameter has been edited, a complete uninterrupted opening-closing cycle is required. WARNING: when the display reads "SET", obstacle detection is not active.
cLd iStSLoUd	0	50	10		Slow-down distance during closing [%]	Slow-down distance for motor(s) during closing, given as a percentage of total travel. WARNING: Once the parameter has been edited, a complete uninterrupted opening-closing cycle is required. WARNING: when the display reads "SET", obstacle detection is not active.
d iStdEcEL	0	50	15		Deceleration distance [%]	Deceleration distance (switch from running speed to slow-down speed) for motor(s) both during opening and during closing, given as a percentage of total travel. WARNING: Once the parameter has been edited, a complete uninterrupted opening-closing cycle is required. WARNING: when the display reads "SET", obstacle detection is not active.
oPForcE	1	99	50		Leaf force during opening [%]	Force exerted by leaf/leaves during opening. This is the percentage of force delivered, beyond the force stored during the autoset cycle (and subsequently updated), before an obstacle alarm is generated. The parameter is set automatically by the autoset function. ⚠ WARNING: It affects impact force directly: make sure that current safety requirements are met with the set value (*). Install anti-crush safety devices where necessary.
cLSForcE	1	99	50		Leaf force during closing [%]	Force exerted by leaf/leaves during closing. This is the percentage of force delivered, beyond the force stored during the autoset cycle (and subsequently updated), before an obstacle alarm is generated. The parameter is set automatically by the autoset function. ⚠ WARNING: It affects impact force directly: make sure that current safety requirements are met with the set value (*). Install anti-crush safety devices where necessary.
oP SPEED	15	99	99		Opening speed [%]	Percentage of maximum speed that can be reached by motor(s) during opening. WARNING: Once the parameter has been edited, a complete uninterrupted opening-closing cycle is required. WARNING: when the display reads "SET", obstacle detection is not active.
cL SPEED	15	99	99		Closing speed [%]	Percentage of maximum speed that can be reached by motor(s) during closing. WARNING: Once the parameter has been edited, a complete uninterrupted opening-closing cycle is required. WARNING: when the display reads "SET", obstacle detection is not active.
SLow SPEED	15	99	25		Slow-down speed [%]	Opening and closing speed of motor(s) during slow-down stage, given as a percentage of maximum running speed. WARNING: Once the parameter has been edited, a complete uninterrupted opening-closing cycle is required. WARNING: When the display reads ""SET"", obstacle detection is not active.

(*) In the European Union, apply standard EN 12453 for force limitations, and standard EN 12445 for measuring method.

INSTALLATION MANUAL

TABLE "B" - LOGIC MENU - (Logic)

Logic	Default	Definition	Cross out setting used	Description				
Motor type	0	Motor type Set the type of motor connected to the board.	0	Motors not active				
			1	ELI 250 BT				
			2	PHOBOS BT				
			3	IGEA BT				
TCA	0	Automatic Closing Time	0	Logic not enabled				
			1	Switches automatic closing on				
FAST CLS.	0	Fast closing	0	Logic not enabled				
			1	Closes 3 seconds after the photocells are cleared before waiting for the set TCA to elapse.				
STEP-BY-STEP movement	0	Step-by-step movement	0	Inputs configured as Start E, Start I, Ped operate with 4-step logic.				
			1	Inputs configured as Start E, Start I, Ped operate with 3-step logic. Pulse during closing reverses movement.	step-by-step mov.			
						2 STEP	3 STEP	4 STEP
			2	Inputs configured as Start E, Start I, Ped operate with 2-step logic. Movement reverses with each pulse.	CLOSED	OPENS	OPENS	OPENS
					DURING CLOSING	OPENS	OPENS	STOPS
			DURING OPENING	CLOSES	CLOSES	CLOSES		
AFTER STOP	OPENS	OPENS		OPENS				
PRE-ALARM	0	Pre-alarm	0	The flashing light comes on at the same time as the motor(s) start.				
			1	The flashing light comes on approx. 3 seconds before the motor(s) start.				
hold-to-run	0	Deadman	0	Pulse operation.				
			1	Deadman mode. Input 61 is configured as OPEN UP. Input 62 is configured as CLOSE UP. Operation continues as long as the OPEN UP or CLOSE UP keys are held down.  WARNING: safety devices are not enabled.				
			2	Emergency Deadman mode. Usually pulse operation. If the board fails the safety device tests (photocell or safety edge, Er0x) 3 times in a row, the device is switched to Deadman mode, which will stay active until the OPEN UP or CLOSE UP keys are released. Input 61 is configured as OPEN UP. Input 62 is configured as CLOSE UP.  WARNING: with the device set to Emergency Deadman mode, safety devices are not enabled.				
block open	0	Block pulses during opening	0	Pulse from inputs configured as Start E, Start I, Ped has effect during opening.				
			1	Pulse from inputs configured as Start E, Start I, Ped has no effect during opening.				
block TCA	0	Block pulses during TCA	0	Pulse from inputs configured as Start E, Start I, Ped has effect during TCA pause.				
			1	Pulse from inputs configured as Start E, Start I, Ped has no effect during TCA pause.				
PRESS SWC	0	Closing limit switch pressure	0	Movement is stopped only when the closing limit switch trips: in this case, the tripping of the closing limit switch must be adjusted accurately (Fig.G Ref.B).				
			1	Use when there is a mechanical stop in closed position. This function allows leaves to press against the mechanical stop without the Amperostop sensor interpreting this as an obstacle. Thus the rod continues its stroke for a few seconds after meeting the closing limit switch or as far as the mechanical stop. In this way, the leaves come to rest perfectly against the stop by allowing the closing limit switches to trip slightly earlier (Fig.G Ref.A).				
1 motor on	0	1 motor active	0	Both motors active (2 leaves).				
			1	Only motor 1 active (1 leaf).				
open in other direction	0	Open in other direction	0	Standard operating mode (See Fig.G Ref.C).				
			1	Opens in other direction to standard operating mode (See Fig.G Ref.D).				
SAFE 1	0	Configuration of safety input SAFE 1. 72	0	Input configured as Phot (photocell).				
			1	Input configured as Phot test (tested photocell).				
			2	Input configured as Phot op (photocell active during opening only).				
			3	Input configured as Phot op test (tested photocell active during opening only).				
			4	Input configured as Phot cl (photocell active during closing only).				
			5	Input configured as Phot cl test (tested photocell active during closing only).				
			6	Input configured as Bar, safety edge.				
			7	Input configured as Bar, tested safety edge.				
			8	Input configured as Bar 8k2.				
SAFE 2	6	Configuration of safety input SAFE 2. 74	0	Input configured as Phot (photocell).				
			1	Input configured as Phot test (tested photocell).				
			2	Input configured as Phot op (photocell active during opening only).				
			3	Input configured as Phot op test (tested photocell active during opening only).				
			4	Input configured as Phot cl (photocell active during closing only).				
			5	Input configured as Phot cl test (tested photocell active during closing only).				
			6	Input configured as Bar, safety edge.				
			7	Input configured as Bar, tested safety edge.				
			8	Input configured as Bar 8k2.				

INSTALLATION MANUAL

D811762 00100_02

IC 1	0	Configuration of command input IC 1. 61	0	Input configured as Start E.
			1	Input configured as Start I.
			2	Input configured as Open.
			3	Input configured as Close.
			4	Input configured as Ped.
			5	Input configured as Timer.
			6	Input configured as Timer Pedestrian.
IC 2	4	Configuration of command input IC 2. 62	0	Input configured as Start E.
			1	Input configured as Start I.
			2	Input configured as Open.
			3	Input configured as Close.
			4	Input configured as Ped.
			5	Input configured as Timer.
			6	Input configured as Timer Pedestrian.
AUX 3	0	Configuration of AUX 3 output. 26-27	0	Output configured as 2nd Radio Channel.
			1	Output configured as SCA (gate open light).
			2	Output configured as Courtesy Light command.
			3	Output configured as Zone Light command.
			4	Output configured as Stair Light
			5	Output configured as Alarm
			6	Output configured as Flashing light
			7	Output configured as Latch
			8	Output configured as Magnetic lock
Fixed code	0	Fixed code	0	Receiver is configured for operation in rolling-code mode. Fixed-Code Clones are not accepted.
			1	Receiver is configured for operation in fixed-code mode. Fixed-Code Clones are accepted.
Radio Prog	1	Transmitter programming	0	Disables wireless memorizing of transmitters. Transmitters are memorized only using the relevant Radio menu. IMPORTANT: Disables the automatic addition of new transmitters, clones and replays.
			1	Enables wireless memorizing of transmitters: 1- Press in sequence the hidden key and normal key (T1-T2-T3-T4) of a transmitter that has already been memorized in standard mode via the radio menu. 2- Press within 10s the hidden key and normal key (T1-T2-T3-T4) of a transmitter to be memorized. The receiver exits programming mode after 10s: you can use this time to enter other new transmitters. This mode does not require access to the control panel. IMPORTANT: Enables the automatic addition of new transmitters, clones and replays.
Serial Mode	0	Serial mode Identifies how board is configured in a BFT network connection	0	Standard SLAVE: board receives and communicates commands/diagnostics/etc.
			1	Standard MASTER: board sends activation commands (START, OPEN, CLOSE, PED, STOP) to other boards.
Address	0	Address	[___]	Identifies board address from 0 to 127 in a local BFT network connection.
EXPI1	1	Configuration of EXPI1 input on input-output expansion board 1-2	0	Input configured as Start E command.
			1	Input configured as Start I command.
			2	Input configured as Open command.
			3	Input configured as Close command.
			4	Input configured as Ped command.
			5	Input configured as Timer command.
			6	Input configured as Timer Pedestrian command.
			7	Input configured as Phot (photocell) safety.
			8	Input configured as Phot op safety (photocell active during opening only).
			9	Input configured as Phot cl safety (photocell active during closing only).
			10	Input configured as Bar safety (safety edge).
			11	Input configured as Phot test safety (tested photocell). Input 3 (EXPI2) on input/output expansion board is switched automatically to safety device test input, EXPFAULT1.
			12	Input configured as Phot op test safety (tested photocell active during opening only). Input 3 (EXPI2) on input/output expansion board is switched automatically to safety device test input, EXPFAULT1.
			13	Input configured as Phot cl test safety (tested photocell active during closing only). Input 3 (EXPI2) on input/output expansion board is switched automatically to safety device test input, EXPFAULT1.
			14	Input configured as Bar safety (tested safety edge). Input 3 (EXPI2) on input/output expansion board is switched automatically to safety device test input, EXPFAULT1.

INSTALLATION MANUAL

EHP02	0	Configuration of EXPI2 input on input-output expansion board 1-3	0	Input configured as Start E command.
			1	Input configured as Start I command.
			2	Input configured as Open command.
			3	Input configured as Close command.
			4	Input configured as Ped command.
			5	Input configured as Timer command.
			6	Input configured as Timer Pedestrian command.
			7	Input configured as Phot (photocell) safety.
			8	Input configured as Phot op safety (photocell active during opening only).
			9	Input configured as Phot cl safety (photocell active during closing only).
			10	Input configured as Bar safety (safety edge).
EHP01	9	Configuration of EXPO2 output on input-output expansion board 4-5	0	Output configured as 2nd Radio Channel.
			1	Output configured as SCA (gate open light).
			2	Output configured as Courtesy Light command.
			3	Output configured as Zone Light command.
			4	Output configured as Stair Light.
			5	Output configured as Alarm.
			6	Output configured as Flashing light.
			7	Output configured as Latch.
			8	Output configured as Magnetic lock.
			9	Output configured as Traffic Light control with TLB board.
EHP02	9	Configuration of EXPO2 output on input-output expansion board 6-7	0	Output configured as 2nd Radio Channel.
			1	Output configured as SCA (gate open light).
			2	Output configured as Courtesy Light command.
			3	Output configured as Zone Light command.
			4	Output configured as Stair Light.
			5	Output configured as Alarm.
			6	Output configured as Flashing light.
			7	Output configured as Latch.
			8	Output configured as Magnetic lock.
			9	Output configured as Traffic Light control with TLB board.
ErAFF ic Light PrEFFLASH ing	0	Traffic light pre-flashing	0	Pre-flashing switched off.
			1	Red lights flash, for 3 seconds, at start of operation.
ErAFF ic Light rEd LAMP AL- LAYS on	0	Steadily lit red light	0	Red lights off when gate closed.
			1	Red lights on when gate closed.

TABLE "C" – RADIO MENU (rRd id)

Logic	Description
Add Start	Add Start Key associates the desired key with the Start command
Add 2ch	Add 2ch Key associates the desired key with the 2nd radio channel command
ErASE 54	Erase List  WARNING! Erases all memorized transmitters from the receiver's memory.
cod rH	Read receiver code Displays receiver code required for cloning transmitters.
Wk	ON = Enables remote programming of cards via a previously memorized W LINK transmitter. It remains enabled for 3 minutes from the time the W LINK transmitter is last pressed. OFF = W LINK programming disabled.

BFT S.P.A.

Via Lago di Vico 44, 36015 Schio (Vi) - *Italy*
tel. +39 0445 69 65 11 / fax. +39 0445 69 65 22
www.bft.it / e-mail: info@bft.it

AUTOMATISMES BFT FRANCE

13 Bd. E. Michelet, 69008 Lyon - *France*
tel. +33 (0)4 78 76 09 88 - fax +33 (0)4 78 76 92 23
e-mail: contacts@automatismes-bft-france.fr

**BFT Torantriebssysteme GmbH**

Faber-Castell-Straße 29
D - 90522 Oberasbach - *Germany*
tel. +49 (0)911 766 00 90 - fax +49 (0)911 766 00 99
e-mail: service@bft-torantriebe.de

BFT Automation UK Ltd

Unit 8E, Newby Road
Industrial Estate Hazel Grove, Stockport,
Cheshire, SK7 5DA - *UK*
tel. +44 (0) 161 4560456 - fax +44 (0) 161 4569090
e-mail: info@bftautomation.co.uk

BFT BENELUX SA

Parc Industriel 1, Rue du commerce 12
1400 Nivelles - *Belgium*
tel. +32 (0)67 55 02 00 - fax +32 (0)67 55 02 01
e-mail: info@bftbenelux.be

BFT-ADRIA d.o.o.

Obrovac 39
51218 Dražice (Rijeka)
Hrvatska - *Croatia*
tel. +385 (0)51 502 640 - fax +385 (0)51 502 644
e-mail: info@bft.hr

BFT Polska Sp. z o.o.

ul. Kołocińska 35
03-171 Warszawa - *Poland*
tel. +48 22 814 12 22 - fax +48 22 814 39 18
e-mail: biuro@bft.com.pl

BFT USA BFT U.S., Inc.

6100 Broken Sound Pkwy. N.W., Suite 14
Boca Raton, FL 33487 - *U.S.A.*
T: +1 561.995.8155 - F: +1 561.995.8160
TOLL FREE 1.877.995.8155 - info.bft@bft-usa.com

BFT GROUP ITALIBERICA DE AUTOMATISMOS S.L.

Pol. Palou Nord,
Sector F - C/Cami - Can Basa nº 6-8 08401 Granollers -
(Barcelona) - Spain
tel. +34 938 61 48 28 - fax +34 938 70 03 94
e-mail: bftbcn@bftautomatismos.com

Pl. Comendador - C/
informática, Nave 22 - 19200 Azuqueca de henares
(Guadalajara) - Spain
tel. +34 949 26 32 00 - fax +34 949 26 24 51
e-mail: administracion@bftautomatismos.com

BFT SA-COMERCIO DE AUTOMATISMOS E MATERIAL DE SEGURANÇA
Urbanizaçao da Pedrulha Lote 9 - Apartado 8123,
3020-305 COIMBRA - *PORTUGAL*
tel. +351 239 082 790 - fax +351 239 082 799
e-mail: geral@bftportugal.com